

Toshiba Global Commerce Solutions  
SureMark 4610 Printers

# Hardware Guide

## Model 1NR

Note:

Before using this information and the product it supports, be sure to read [Safety Information](#), [Warranty Information](#), [Uninterruptible Power Supply Information](#), and the information under [Notices](#).

**April 2016**

This edition applies to Toshiba SureMark Printer Model 1NR.

If you send information to Toshiba Global Commerce Solutions (Toshiba), you grant Toshiba a nonexclusive right to use or distribute whatever information you supply in any way it believes appropriate without incurring any obligation to you.

© Copyright Toshiba Global Commerce Solutions, Inc. 2016

---

# Contents

<b>Figures.....</b>	<b>5</b>	<b>Notices.....</b>	<b>39</b>
<b>Tables.....</b>	<b>7</b>	Telecommunication regulatory statement.....	40
<b>Safety.....</b>	<b>9</b>	Electronic emission notices.....	40
<b>About this guide.....</b>	<b>11</b>	Federal Communications Commission (FCC)	
Who should read this guide.....	11	statement.....	40
Where to find more information.....	11	FCC Radiation Exposure Statement.....	40
Additional information.....	11	Industry Canada Class A Emission Compliance	
Notice statements.....	11	statement.....	40
<b>Chapter 1. Introducing the 4610</b>		Avis de conformité à la réglementation	
<b>Model 1NR.....</b>	<b>13</b>	d'Industrie Canada.....	41
Features and specifications.....	13	Industry Canada Radiation Exposure Statement.....	41
Communication and power.....	14	European Union Electromagnetic Compatibility	
Network interface adapter prerequisites.....	18	(EMC) Directive Conformance Statement.....	41
Operating system requirements.....	18	Germany Class A statement.....	41
Hardware requirements.....	19	Australia and New Zealand Class A statement.....	42
Understanding the controls and indicators.....	20	Aviso para los usuarios de México.....	42
Locating the power button.....	21	People's Republic of China Class A electronic	
Calling for service.....	22	emission statement.....	42
<b>Chapter 2. Product specifications.....</b>	<b>25</b>	Russian Electromagnetic Interference (EMI) Class	
Physical dimensions.....	25	A statement.....	43
Temperature and humidity limits.....	26	Japanese Electrical Appliance and Material	
<b>Chapter 3. Installing and configuring</b>		Safety Law statement.....	43
<b>the 4610 printer.....</b>	<b>27</b>	Japanese power line harmonics compliance	
Before you begin.....	27	statement.....	43
Understanding your configuration .....	27	Japan Voluntary Control Council for Interference	
Verify your order.....	27	Class A statement.....	43
Installing the interface card.....	27	Japan Electronics and Information Technology	
Routing the cash drawer and RS-485 cables.....	28	Industries Association (JEITA) statement.....	43
Installing the fillers.....	30	Korean communications statement.....	44
Wall (or 45-degree) mounting.....	30	Taiwan Class A compliance statement.....	44
<b>Chapter 4. Using and maintaining</b>		Taiwan contact information.....	44
<b>the 4610 printer.....</b>	<b>35</b>	Cable ferrite requirement.....	45
Replenishing consumable supplies.....	35	Electrostatic discharge (ESD).....	45
Loading and replacing the paper roll.....	35	Product recycling and disposal.....	45
Supported thermal paper.....	35	Battery safety.....	46
Installing large paper rolls.....	36	Battery return program.....	46
Cleaning recommendations.....	36	For Taiwan:.....	47
Cleaning the thermal printhead.....	36	For the European Union:.....	47
Retrieving printer statistics.....	37	For California:.....	48
		Flat panel displays.....	48
		Monitors and workstations.....	48
		Trademarks.....	48



---

# Figures

1. SureMark 4610 printer.....	13
2. USB interface card.....	15
3. RS-232 interface card.....	16
4. RS-485 interface card.....	16
5. Ethernet interface card.....	17
6. WiFi interface card.....	17
7. Indicators and controls.....	20
8. Power button.....	22
9. Location of serial number.....	23
10. SureMark 4610 Model 1NR dimensions.....	25
11. Installing the interface card.....	28
12. Cash drawer cable routing.....	29
13. RS-485 cable routing.....	29
14. Installed WiFi interface with cable routing.....	30
15. Position selector.....	31
16. Wall-mount slots.....	32
17. Mount-release button.....	33
18. Receipt showing usage statistics.....	37



---

## Tables

1. Model feature description .....	14
2. Communication interface, rate, and power source.....	15
3. OS printer interface options.....	18
4. Paper supply LED indicator.....	21
5. Printer ready LED indicator .....	21
6. Ethernet LED indicator.....	21
7. WiFi LED indicator.....	21
8. Summary of dimensions.....	25





---

## Safety

Before installing this product, read [Safety Information](#).

قبل تركيب هذا المنتج، يجب قراءة الملاحظات الأمنية

Antes de instalar este produto, leia as Informações de Segurança.

在安装本产品之前，请仔细阅读 **Safety Information** (安全信息)。

安裝本產品之前，請先閱讀「安全資訊」。

Prije instalacije ovog produkta obavezno pročitajte Sigurnosne Upute.

Před instalací tohoto produktu si přečtěte příručku bezpečnostních instrukcí.

Læs sikkerhedsforskrifterne, før du installerer dette produkt.

Lees voordat u dit product installeert eerst de veiligheidsvoorschriften.

Ennen kuin asennat tämän tuotteen, lue turvaohjeet kohdasta Safety Information.

Avant d'installer ce produit, lisez les consignes de sécurité.

Vor der Installation dieses Produkts die Sicherheitshinweise lesen.

Πριν εγκαταστήσετε το προϊόν αυτό, διαβάστε τις πληροφορίες ασφάλειας (safety information).

לפני שתתקינו מוצר זה, קראו את הוראות הבטיחות.

A termék telepítése előtt olvassa el a Biztonsági előírásokat!

Prima di installare questo prodotto, leggere le Informazioni sulla Sicurezza.

製品の設置の前に、安全情報をお読みください。

본 제품을 설치하기 전에 안전 정보를 읽으십시오.

Пред да се инсталира овој продукт, прочитајте информацијата за безбедност.

Les sikkerhetsinformasjonen (Safety Information) før du installerer dette produktet.

Przed zainstalowaniem tego produktu, należy zapoznać się z książką "Informacje dotyczące bezpieczeństwa" (Safety Information).

Antes de instalar este produto, leia as Informações sobre Segurança.

Перед установкой продукта прочтите инструкции по технике безопасности.

Pred inštaláciou tohto zariadenia si pečítajte Bezpečnostné predpisy.

Pred namestitvijo tega proizvoda preberite Varnostne informacije.

Antes de instalar este producto, lea la información de seguridad.

Läs säkerhetsinformationen innan du installerar den här produkten.



---

## About this guide

This guide contains information about installing, using, and maintaining the Toshiba® SureMark™ 4610 Model 1NR printer.

---

## Who should read this guide

This guide is intended for use by personnel who are installing and using the SureMark 4610 Model 1NR printers.

---

## Where to find more information

For information on Toshiba Global Commerce Solutions products and services, start at <https://www.toshibacommerce.com>. Click on the support link for information on the latest versions of Toshiba Global Commerce Solutions documentation.

**Note:** Access to Toshiba online publications requires an Enterprise ID. For more information, contact your Toshiba representative, or [toshiba\\_comms@toshibagcs.com](mailto:toshiba_comms@toshibagcs.com).

## Additional information

The following publications provide additional information about the SureMark 4610 Models 1NR printer:

- Click *SureMark 4610 Printers: Hardware Service Guide - Models 1NR TC62-0001*.
- *SureMark 4610 Printers: Programming Guide for Models 1xR and 2xR, TC62-0005*

---

## Notice statements

Notices in this guide are defined as follows:

### Notes

These notices provide important tips, guidance, or advice.

### Important

These notices provide information or advice that might help you avoid inconvenient or problem situations.

### Attention

These notices indicate potential damage to programs, devices, or data. An attention notice is placed just before the instruction or situation in which damage could occur.

### CAUTION

These statements indicate situations that can be potentially hazardous to you. A caution statement is placed just before the description of a potentially hazardous procedure step or situation.

### DANGER

These statements indicate situations that can be potentially lethal or extremely hazardous to you. A danger statement is placed just before the description of a potentially lethal or extremely hazardous procedure step or situation.



---

## Chapter 1. Introducing the 4610 Model 1NR

The SureMark 4610 Printer Model 1NR is single-station thermal printer designed for ease use and service. With a print speed of 80 lines per second (LPS) and a 4-inch paper roll diameter, this high-speed printer lets you quickly print long receipts, monitor paper status, and gather printer usage statistics.

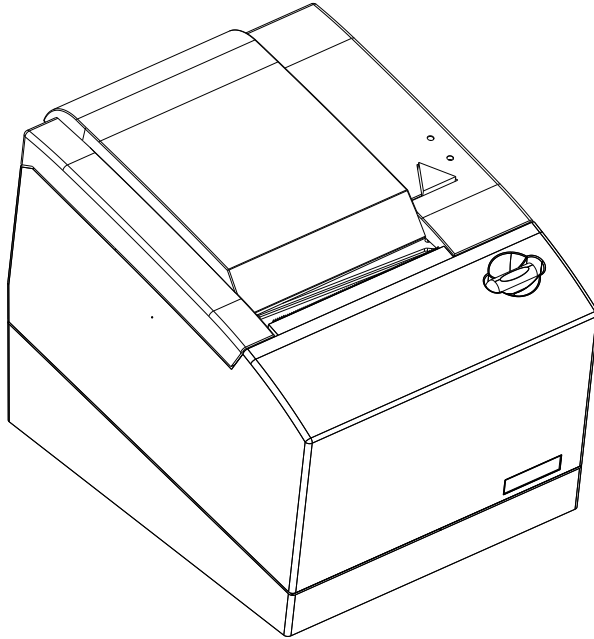

Figure 1. SureMark 4610 printer

---

### Features and specifications

The key features of the Model 1NR include:

- Print speeds of 80 lines per second (LPS)
- One-hand paper loading with the touch of a button
- 4 inch thermal paper roll
- System management sensors that alert you to:
  - Close the cover on the printer
  - Replace the receipt paper
  - Status of the printhead
  - Printer usage statistics
- Beeper
- Quiet paper cutter
- USB, RS-232, RS-485, Ethernet, and WiFi interfaces
- 3 MB flash memory for storing messages, logos, code pages, and electronic journal data
- DBCS thermal font - 24x24 matrix
- Bar code generation
- Downloadable fonts and code pages
- Downloadable microcode
- Small footprint
- Wall mount

Table 1. Model feature description

Features	SureMark 4610 Model 1NR
Print method	Thermal
Command sets	Native, Epson emulation (RS-232, and network attached), direct, compatibility mode (Tx6/Tx7)
Communication interface	RS-232 - 115 kbps RS-485 - 187 kbps USB 1.1 (USB 2.0 compatible) Ethernet - 10/100 Mbps WiFi - 802.11 a/b/g/n/ac
Paper support	58 mm or 80 mm single- or two-color, 102 mm (4 in.) maximum outer diameter internal roll, 12 in. external supply
Print speed	Up to 80 LPS (one-color)
Dot pitch	203 dpi
User memory	3 MB Flash
Ports	DC In (except RS-485), USB/Powered USB or RS-232 or RS-485 (24 V or 38 V) or Ethernet (interface card-specific), OEM cash drawer (+24 V)
Power options	System Unit: 24 V or 38 V (interface card-specific) Brick: 24 V
Color	Iron gray or pearl white (two-tone color not provided)
Controls and indicators	Cover Open, Paper Feed, Beeper, Status LED (bi-color), Paper Status LED, Power Switch
Mounting	Integrated (Integration tray), Distributed (free standing), Wall mount
Operating systems	POSReady 2009, POSReady 7, Windows 7, Windows 8.1, Windows 10, 4690 OS, Linux, iOS, Android
Drivers	Native Windows, UPOS (OPOS and JavaPOS™), 4690 OS
Receipt paper loading	Drop and load
Receipt paper cutter	Standard
Receipt tear bar	Yes
Rotate print (line by line)	Yes
DBCS thermal font - 24x24 matrix	Yes

## Communication and power

An interface card is shipped with the SureMark 4610™ printers to provide communication to the system unit. Depending on your connectivity requirements, you will have one of the cards listed in [Table 2](#).

Table 2. Communication interface, rate, and power source

Device	Description	Power®
USB	USB is 2.0 Compliant Full Speed HID; Bulk transfers at 12 Mbps (Mega bits per second)	System unit input voltage (+24 V); separate power supply if standard USB connector is used
RS-485	Toshiba proprietary	System unit input voltage +38 V or +24 V (Japan only)
RS-232	9.6K - 115.2K (selectable using offline or online configuration) Baud rate	Separate power supply
Ethernet	10/100 Ethernet port for connection to an industry standard Ethernet LAN	Separate power supply
WiFi	801.11 a/b/g/n/ac Wireless LAN Adapter	Separate power supply

Figure 2 illustrates the different communications connections on the USB interface card.

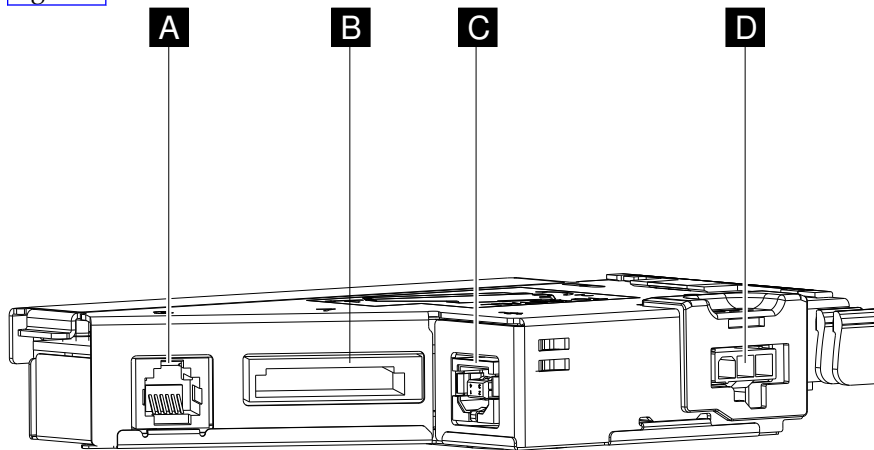

Figure 2. USB interface card

Device	Description
<b>A</b>	Cash drawer
<b>B</b>	Powered USB
<b>C</b>	Standard USB
<b>D</b>	Power supply

Figure 3 illustrates the communications connections on the RS-232 interface card.

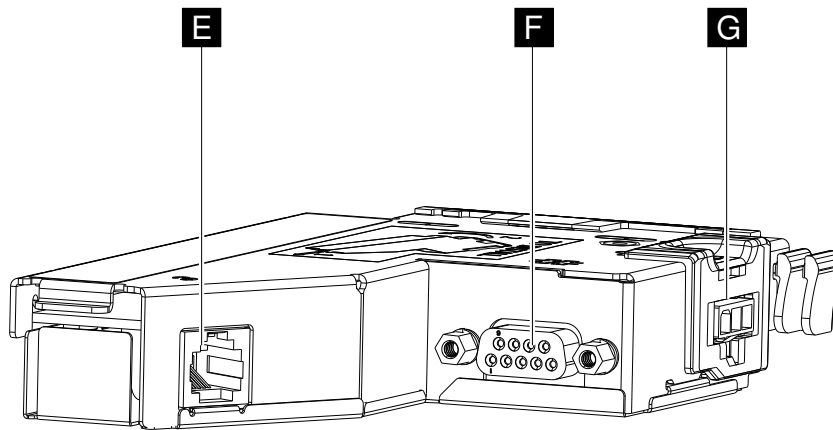

Figure 3. RS-232 interface card

Device	Description
<b>E</b>	Cash drawer
<b>F</b>	RS-232
<b>G</b>	Power supply

Figure 4 illustrates the communications connections on the RS-485 interface card.

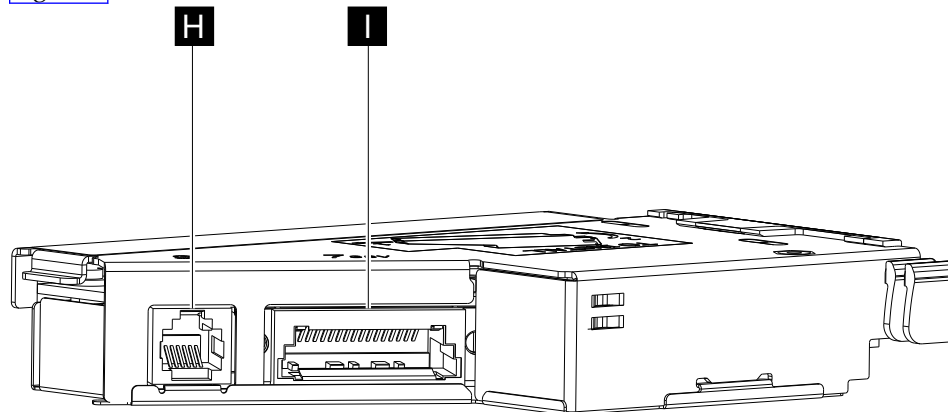

Figure 4. RS-485 interface card

Device	Description
<b>H</b>	Cash drawer
<b>I</b>	RS-485

Figure 5 illustrates the communications connections on the Ethernet interface card.



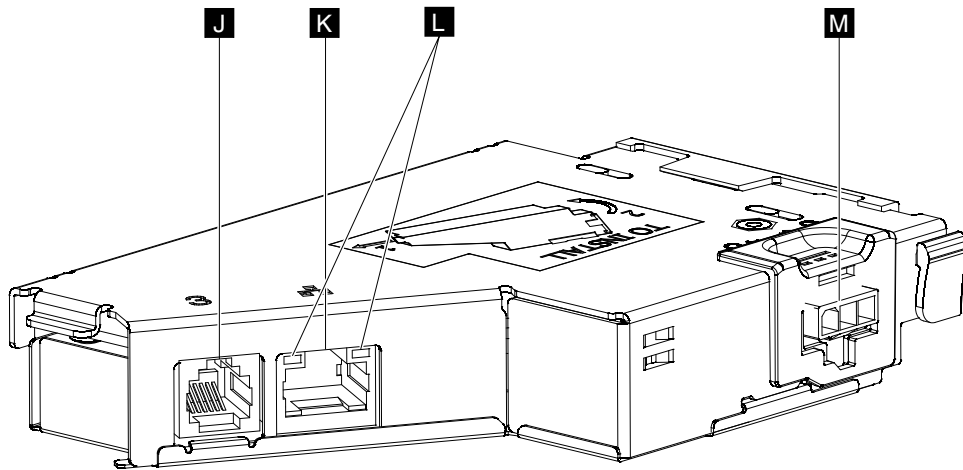

Figure 5. Ethernet interface card

Device	Description
<b>J</b>	Cash drawer
<b>K</b>	Ethernet
<b>L</b>	Ethernet status indicators
<b>M</b>	Power supply

Figure 6 illustrates the communications connections on the WiFi interface card:

- Frequency Band of 802.11 b/g/n - 2.4 Ghz, power 18.30 dBm
- Frequency Band of 802.11 a/n/ac - 5 Ghz, power 19.12dBm

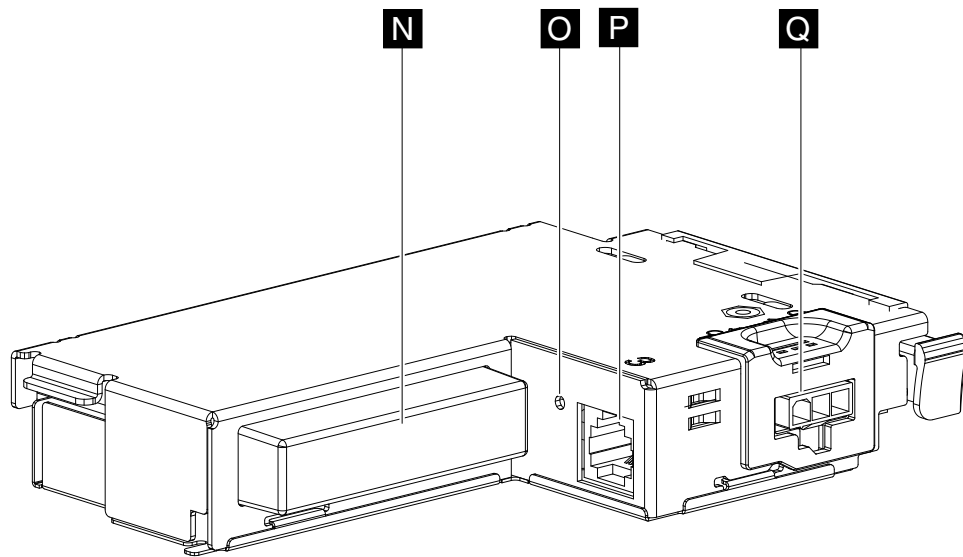

Figure 6. WiFi interface card

Device	Description
<b>N</b>	WiFi
<b>O</b>	WiFi status indicator

Device	Description
<b>P</b>	Cash drawer
<b>Q</b>	Power supply

## Network interface adapter prerequisites

The network interface adapters (Ethernet and WiFi) have dependencies on the level of the printer and printer firmware.

- The printer manufacturing date must be after June 10, 2013. Printers built prior to this date have an older level main logic card (MLC) that will not support these adapters. The manufacturing date is located under the paper cover above the serial number label (see ["Calling for service" on page 22](#)).
- Firmware level 14 and above is required for an Ethernet interface adapter.
- Firmware level 18 and above is required for a WiFi interface adapter. EC firmware level 17.xx will enable basic function, but will not match the function that is described in this manual. These firmware levels will print a message as part of a test receipt that indicates the firmware should be upgraded.

**Note:** The required firmware levels referenced above will not allow back leveling to a version that does not fully support the installed adapter.

**Important:** If a network interface adapter is installed in a printer and the printer has back level firmware or a MLC that does not support it, the printer will indicate an error:

- The ready light will blink amber with the internal LED#2, which indicates that the printer firmware is back level. If the firmware is known to be at the minimum level identified, then this condition indicates a failed adapter or other HW problem.
- A message is printed in the receipt station that the MLC card does not support network adapters, which indicates that the MLC is back level and cannot be used with the installed adapter.

---

## Operating system requirements

You can download drivers from the Toshiba Global Commerce Solutions support website: [www.toshibacommerce.com/support](http://www.toshibacommerce.com/support).

The printer provides a compatibility mode to enable use of older drivers and applications with only minor modifications. The default operating system is referred to as "Native Mode." "Native Mode" provides functional enhancements and is supported by the most current applications and drivers.

[Operating system requirements](#) includes a list of the printer interface options that are supported for each OS/Driver combination.

*Table 3. OS printer interface options*

OS	Driver/API					
	4690 API	JavaPOS Drivers 1.14.0 or later	OPOS Drivers 1.14.0 or later	OPOS Drivers 1.14.0 or later	OPOS Drivers 1.14.0 or later	Direct IO
4690	USB RS485	All				

OS	Driver/API					
	4690 API	JavaPOS Drivers 1.14.0 or later	OPOS Drivers 1.14.0 or later	OPOS Drivers 1.14.0 or later	OPOS Drivers 1.14.0 or later	Direct IO
POSReady 2009		All	All	All	USB RS232 Ethernet WiFi	RS232 Ethernet WiFi
Windows 7		All	All	All	USB RS232 Ethernet WiFi	RS232 Ethernet WiFi
POSReady 7		All	All	All	USB RS232 Ethernet WiFi	RS232 Ethernet WiFi
Windows Embedded 8.1 Pro/Industry (64-bits only)		All	All	All	USB RS232 Ethernet WiFi	RS232 Ethernet WiFi
Windows 8.1 Pro/Enterprise (64-bits only)		All	All	All	USB RS232 Ethernet WiFi	RS232 Ethernet WiFi
Windows 10 Pro/Enterprise		All	All	All	USB RS232 Ethernet WiFi	RS232 Ethernet WiFi
SUSE Linux Enterprise 11 SP1 (SLE 11)		All				RS232 Ethernet WiFi
PC DOS 2000						RS232

**Note:**

1. Toshiba 4610 Ethernet Printer iOS SDK is supported with iOS 8.x or later for use with the Ethernet and WiFi interface adapters.
2. Toshiba 4610 Ethernet Printer Android SDK is supported with Android 4.0 or later for use with the Ethernet and WiFi interface adapters.
3. Only those items listed are supported.

---

## Hardware requirements

SureMark printers work with the following systems:

- 4694 systems
- 4695 systems (RS-232 connection only and with power supply)
- PC or other store controller with an RS-232, Ethernet, WiFi, or USB port
- SurePOS™ 100 Series systems
- SurePOS 300 Series systems
- SurePOS 500 Series systems
- SurePOS 700 Series systems
- Self Checkout solution
- AnyPlace™ Kiosk
- TCx™ Wave
- TCx700
- TCx300
- TCxFlight
- iOS, Android, and Windows mobile devices

---

## Understanding the controls and indicators

This section describes the controls and indicators.

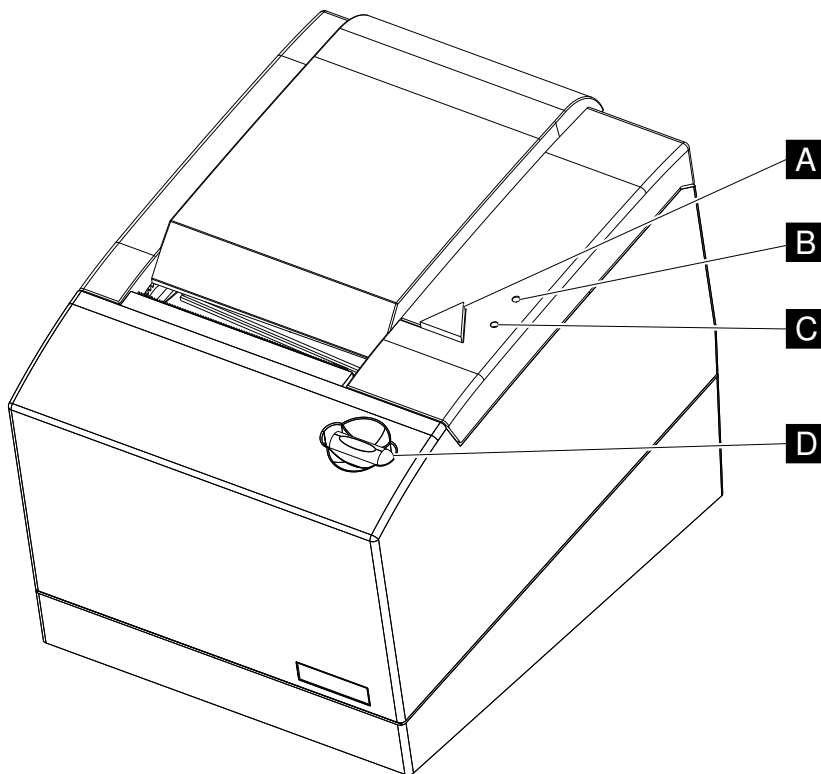

Figure 7. Indicators and controls

Device	Description
<b>A</b>	Paper feed button; press to advance the customer receipt paper.
<b>B</b>	Paper supply LED indicator. See <a href="#">Table 4</a>
<b>C</b>	Printer ready LED indicator. See <a href="#">Table 5</a>

Device	Description
<b>D</b>	Paper door release button

Table 4. Paper supply LED indicator

LED indicator ( <b>B</b> )		
Amber	On	Paper out
	Off	Paper sufficient
	Blinking	Critically low paper supply

Table 5. Printer ready LED indicator

Printer ready ( <b>C</b> )		
Amber	Blinking (0.5s on / 0.5s off)	Station not ready; recoverable error - paper jam, cover open, cutter jam
	Blipping (0.25s on / 1.75s off)	Offline or hardware failure: Cannot communicate with paper motion sensor or the thermal printhead; MLC or IFC problem
Green	On	Station is ready

Table 6 describes the Ethernet LED indicators that reflect printer status.

Table 6. Ethernet LED indicator

Color	State	Function
Green	Off - No link	Ethernet Good Link / Activity
	On - Good link	
	Blinking - Network activity	
Amber	Off - 10 MB mode	Ethernet 10/100Mb
	On - 100 MB mode	

Table 7 describes the indicators that reflect the status of the WiFi connection.

Table 7. WiFi LED indicator

Color	State	Function
Amber	Off - No link	WiFi connected
	On - Link up	

## Locating the power button

The power button ( **A** in Figure 8) for the 4610 Model 1NR is located under the paper door.

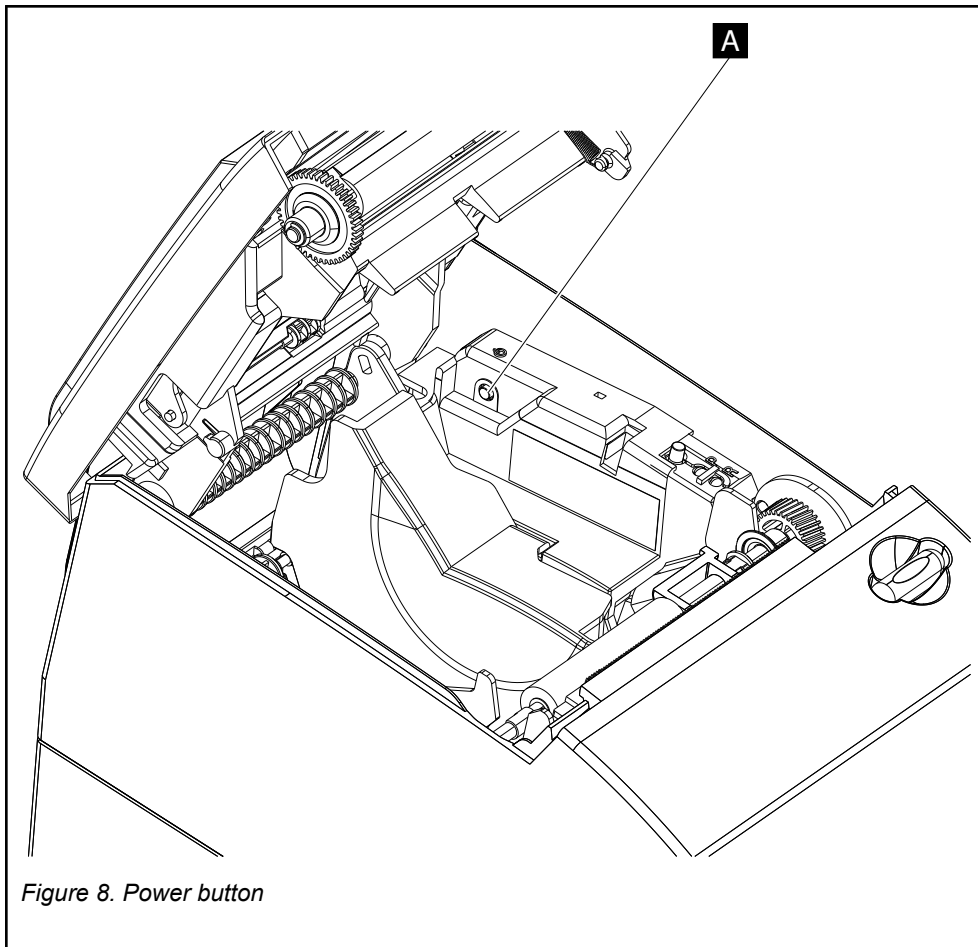
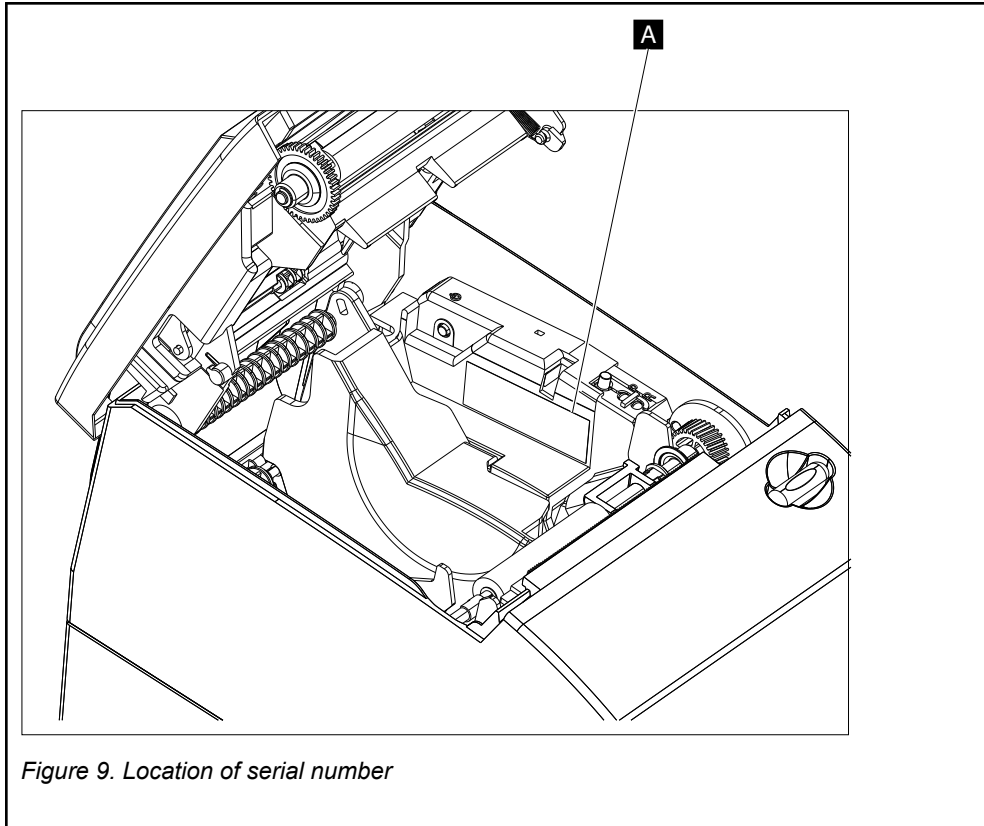

Figure 8. Power button

---

## Calling for service

When you call Toshiba for warranty information or service, be sure to have the serial number and model number of the printer available. The serial number and model number are located beside the flipper door (see **A** in [Figure 9](#)).



*Figure 9. Location of serial number*





# Chapter 2. Product specifications

This section describes the physical specifications for models 1NR.

## Physical dimensions

Figure 10 describes the physical dimensions.

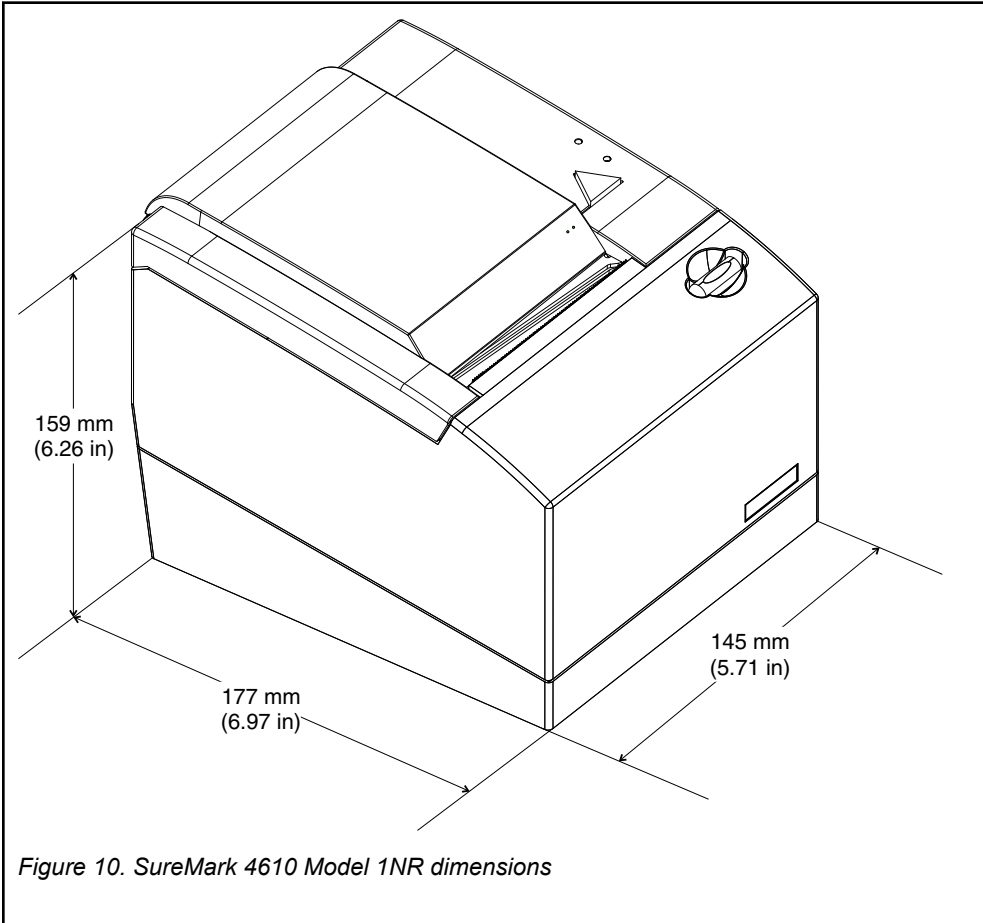

Table 8. Summary of dimensions

Width:	145 mm (5.71 in.) footprint
Height:	Cover closed: 159 mm (6.26 in.)
	Cover open: 260 mm (10.24 in.)
Depth:	177 mm (6.97 in.)
Weight:	1.4 kg (3.09 lb)

---

## Temperature and humidity limits

### Shipping

-40° to 60° C (-40° to 140° F) with 5% to 100% relative humidity including condensation, but excluding rain

### Storage

0° to 60° C (32° to 140° F) with 5% to 80% relative humidity

### Operating

5° to 40° C (42.8° to 104° F) with 8% to 80% relative humidity

---

## Chapter 3. Installing and configuring the 4610 printer

This section provides safety information and steps on installing your printer.

---

### Before you begin

Before you install your SureMark printer, be sure to read this section and the [Safety Information](#) guide.

---

### Understanding your configuration

Your printer can be set up in either an integrated or distributed configuration. An *integrated* configuration is one in which all parts of a system are assembled in one location. A *distributed* configuration is one in which you set up parts of the system in different physical locations. In an integrated configuration, you install the printer on the input/output tray option with the fillers to contain the printer and display on top of the wide-footprint system units. Other tray options include mounting the printer on the full-size cash drawer or directly on the counter.

---

### Verify your order

Each order contains the following:

- 4610 unit
- Interface card (RS-232, RS-485, USB, WiFi, or Ethernet)
- Safety manual
- Warranty statement
- Customer options, such as fillers, cables, and power bricks (packaged separately)

---

### Installing the interface card

The interface card (either an RS-232, RS-485, USB, Ethernet, or WiFi interface) is shipped in a separate box with your printer. Install the interface card as follows:

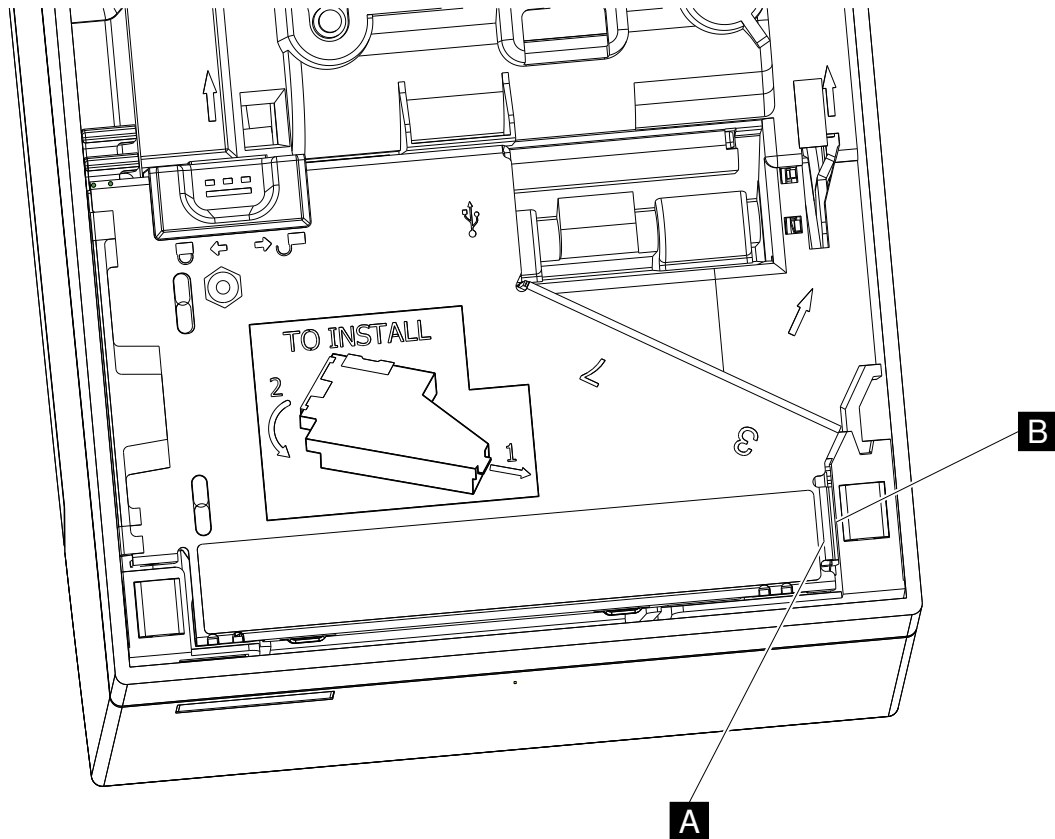

Figure 11. Installing the interface card

1. As shown in [Figure 11](#), place the printer unit upside down.
2. Insert the tab of the interface card (**A**) into the slot on the base of the printer (**B**).
3. Press down on the side of the interface card opposite the tab until the blue release button slider snaps into place.
4. Connect the printer with your system unit or network (RS-232, RS-485, USB, or Ethernet connector).

**Note:**

1. You might prefer to plug all cables into the interface card before installation; however, **do not** plug in any power until after installation.
2. If you are using an RS-485 interface card, see ["Routing the cash drawer and RS-485 cables"](#) on page 28.
5. If you have a power cord, connect it to the printer.

---

## Routing the cash drawer and RS-485 cables

To route the cash drawer and RS-485 cables together through the back cable slot:

1. Route the cash drawer cable through the cable slot (**A** in [Figure 12](#)).

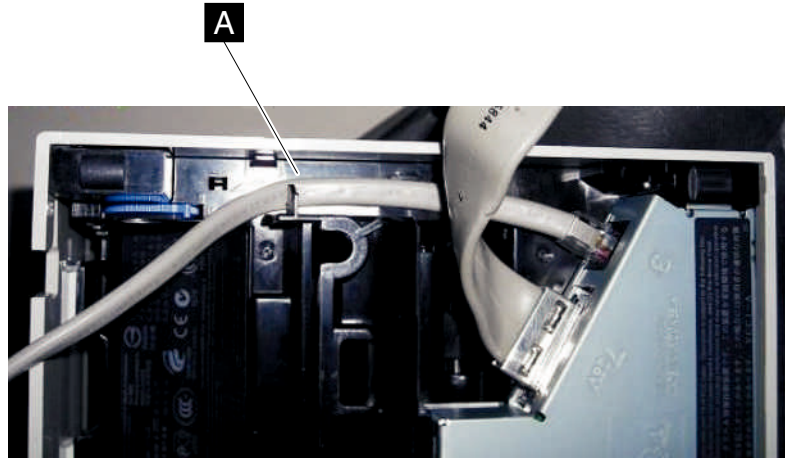

Figure 12. Cash drawer cable routing

2. Route the RS-485 cable (see [Figure 13](#)).
  1. Place the RS485 cable completely down on the base **B**.
  2. Route the cable under the notch **C**.
  3. Route the RS485 cable through the back cable slot **B** and **C** (this is the only possible route).

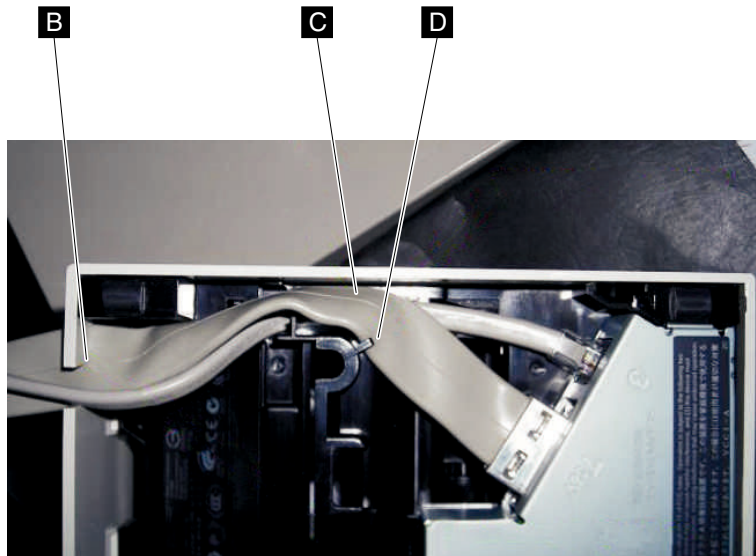

Figure 13. RS-485 cable routing

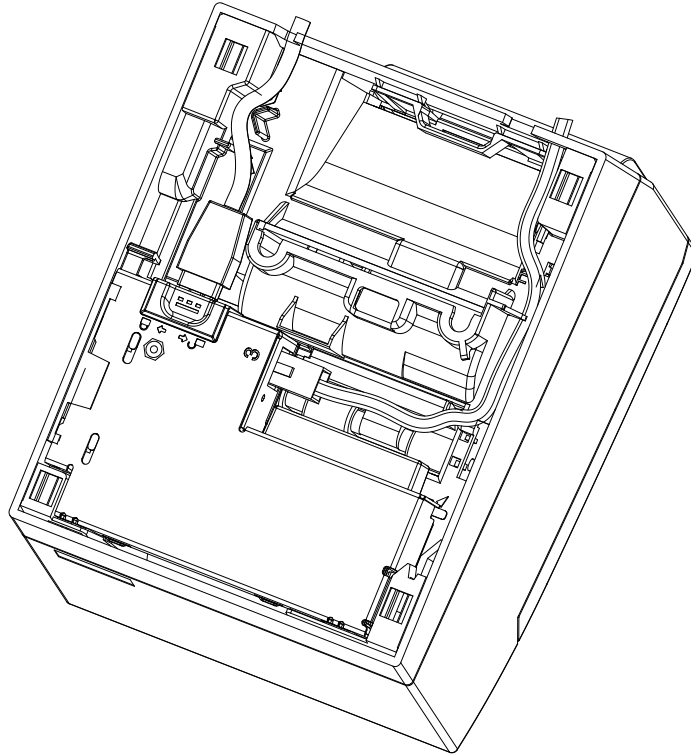

Figure 14. Installed WiFi interface with cable routing

---

## Installing the fillers

The fillers are an important part of your integrated system. They securely position your printer into position with the system unit and other peripherals.

Refer to the installation documentation for your system unit for complete instructions.

---

## Wall (or 45-degree) mounting

**Attention:** Printer must be powered off. The following ESD handling procedure is recommended: You should touch the metal on the printer frame with the back of your hand before making contact with the printer. Also, see ["Electrostatic discharge \(ESD\)" on page 45](#).

Follow these steps to wall (or 45-degree) mount the printer unit:

1. Turn off the power to the 4610.
2. Roll the bottom position selector (part of the low-paper sensor; **A** in [Figure 15](#)) to the WALL position.

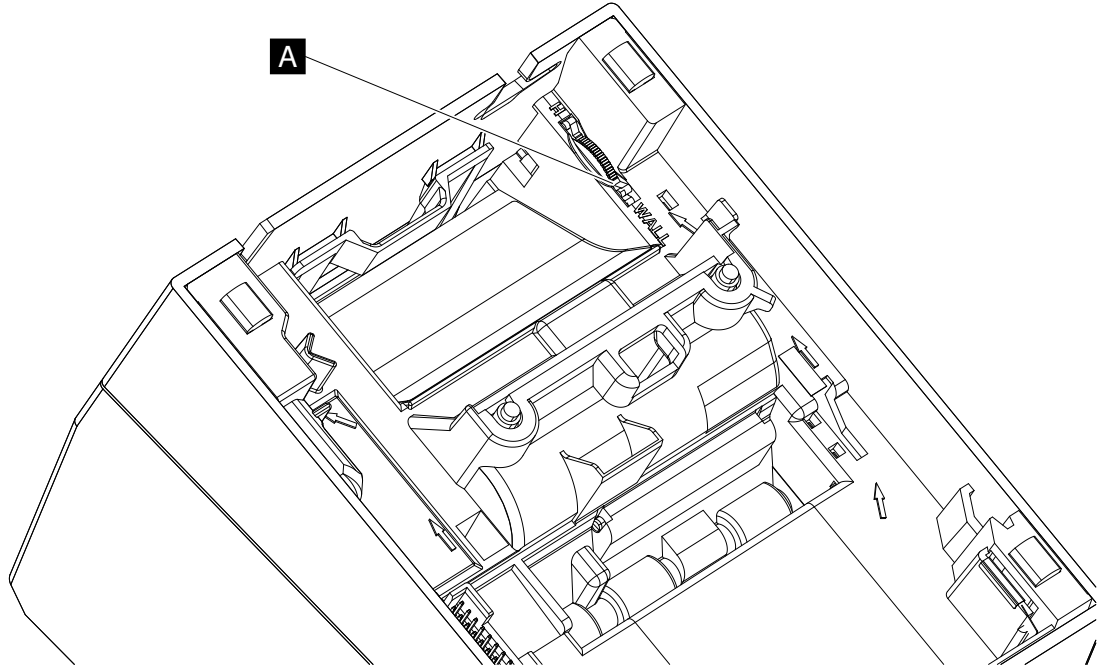

*Figure 15. Position selector*

3. Align the two rounded slots on the base of the printer unit (**A** in [Figure 16](#)) with the two D-shaped posts on the mount. Also, ensure that the hook near the corner of the mount aligns with the slot at the corner of the printer unit (**B**).

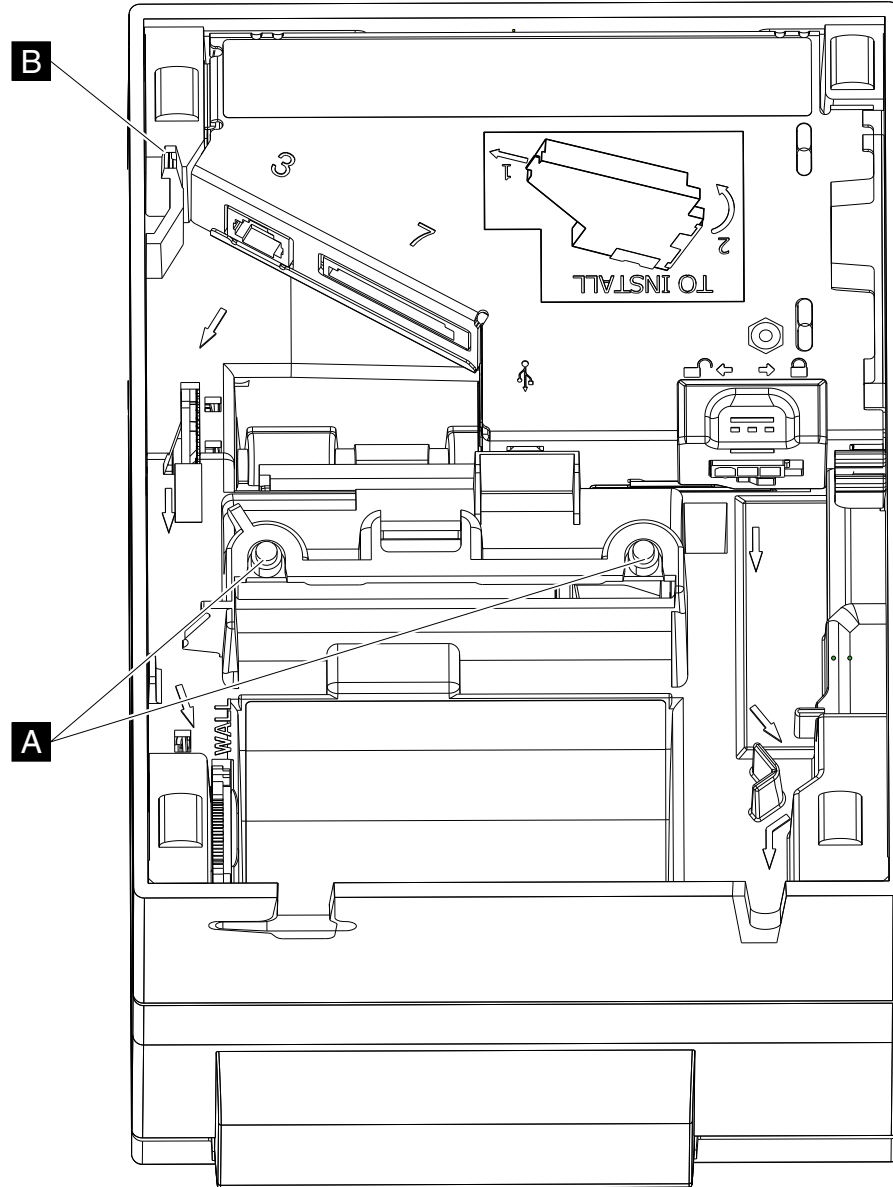

Figure 16. Wall-mount slots

4. Slide the printer unit down (or up) until the mount-release button snaps into place.

To remove the printer unit from the wall mount:

1. Press the door-release button (**D** in Figure 7) and pull (or push) the door fully open.
2. While pushing the mount-release button (**B** in Figure 17) lift (or lower) the printer unit off of the mount posts and hook.



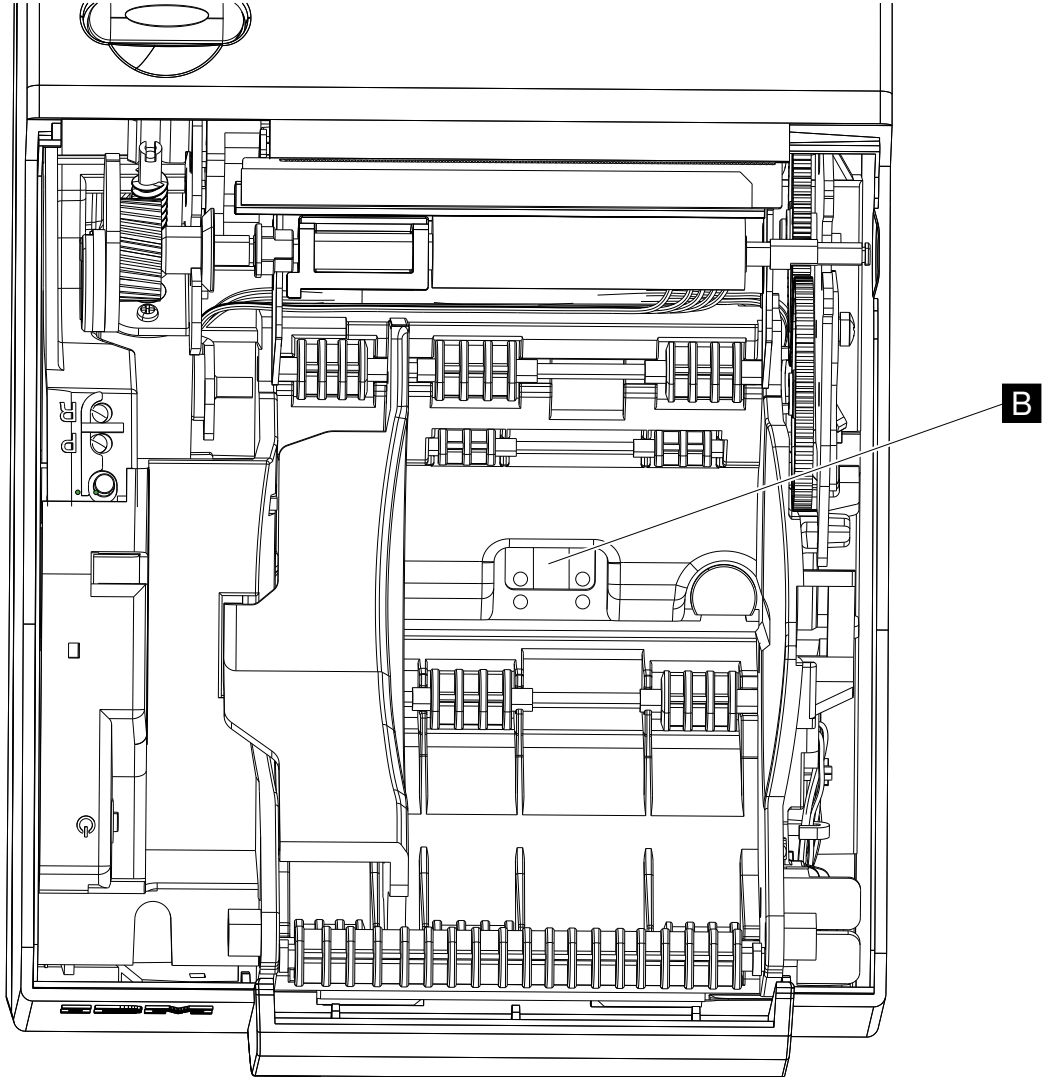

Figure 17. Mount-release button



---

## Chapter 4. Using and maintaining the 4610 printer

This section contains information about the proper use and maintenance of the 4610 Model 1NR. For detailed technical information, see [Chapter 2, Product specifications on page 25](#).

**Attention:** All covers *must* be installed on the SureMark printer during operation.

---

### Replenishing consumable supplies

You are responsible for replenishing consumable supplies, which include the paper rolls.

Make sure that you are using the recommended supplies for the 4610 printer, which are described in the following sections.

### Loading and replacing the paper roll

Ensure that you have the correct paper for the 4610. See ["Supported thermal paper" on page 35](#).

1. Press and release the blue release button to release the paper door. In a wall-mount configuration, you must also pull the door fully open, because of the brake feature that decelerates it from the full force of gravity.
2. If necessary, remove any unused paper or the empty paper roll core before inserting a new paper roll.

**Note:** Refer to the label inside the printer for a diagram of how to load paper.

3. Place the paper roll into the paper roll bucket as shown on the diagram. The leading edge of the paper should come from the bottom of the roll as shown in the diagram.

**Note:** The thermal printhead will not print on paper with glue on it. If the new paper roll was sealed by glue, tear off the 6 to 8 inches of paper with glue on it before loading it.

4. Close the paper cover.
5. Press the customer receipt feed button to advance the paper, to verify that the paper is feeding correctly. Feed 30 cm (about 1 ft) of paper through to test for correct alignment.

**Attention:** Do not pull the receipt paper out of the printer with the paper access cover closed. This disengages the paper feed. The paper feed motor must then catch up before the printer can feed the paper, which causes missing lines or partial lines of print. Use the customer receipt feed button to advance the receipt and all lines will print.

### Supported thermal paper

**Attention:** Using an inferior grade of paper can affect print quality as well as the life of printheads and the printer mechanism.

**Note:** When selecting a paper, ensure that the paper's archive life meets the requirements of the tax authorities of your country for archiving tax-related data.

The paper used in the thermal receipt station must meet the following requirements:

#### Width

79.5 ± 0.5 mm (3.13 ± 0.02 in.) or 57.5 ± 0.5 mm (2.26 ± 0.02 in.)

#### Outside Diameter

102 mm (4.0 in.) maximum

#### Thickness

60 µm (0.00225 in.) optimal. Range: 41 µm minimum to 99 µm maximum.

**Important:** Paper has a significant manufacturing tolerance, and nominal paper designations do not reflect actual measurements. The manufacturing tolerance must fall within the published operating thickness range. Customers should test paper in their specific configuration before use. The intent of this specification is that if any spot measurement of the paper is outside the specified range, the paper is deemed not to meet the specification and the customer is responsible for any problems caused by paper jams.

The paper must be wound with the printing side facing out. The paper should not be attached to the core in any manner.

**Important:**

Printer reliability and performance are directly related to the quality of the supplies used by the customer. The published parameters for printer performance are established using supplies that meet the specifications listed above.

Thermal paper with watermarks, coupons, or advertisements printed on the front or back of the paper **is not covered by Toshiba specifications**. Some inks and printing processes work acceptably, but others do not. Printer problems that are caused by supplies that do not meet Toshiba specifications might result in a billable service call, regardless of the existence of a service contract.

## Installing large paper rolls

The 4610 can accommodate extra-large rolls (up to 15 in.) of paper below the printer. Mounting hardware is necessary to avoid placing undue strain on the paper feed motor. See your Toshiba representative for additional information.

---

## Cleaning recommendations

You should inspect your 4610 unit periodically and clean the cover as required. Use a soft, clean cloth with warm, soapy water to clean the plastic parts. Do not use abrasives or any alkaline, ammonia, or chloride-based cleaner.

**Note:** Do not apply cleaning solution directly to the cover. Always apply the cleaner to a clean cloth and then wipe the cover with the damp cloth. Be certain that the cloth is only damp and not dripping wet.

## Cleaning the thermal printhead

The thermal printhead should be cleaned at regular intervals or when the print quality has noticeably deteriorated. There are many factors that affect cleaning frequency. Poor paper quality, high printer usage, or a dirty environment are all reasons to clean the thermal printhead more often. Complete the following steps to clean the thermal printhead:

1. Open the paper cover.
2. Using a cotton swab soaked in isopropyl alcohol, gently wipe the printhead several times on its print line and on the surrounding area.
3. Wipe off any residual alcohol with a dry swab.

If print quality does not improve after cleaning the thermal printhead, call for service to replace the thermal printhead unit.

**Note:** The type of paper used and the usage rate will increase wear on the thermal printhead.



- Number of steps performed by the CR paper feed motor (200 steps per inch of paper)
- Number of times the customer receipt cover was opened
- Number of failed paper cuts
- Number of Flash Erase commands performed (NVRAM write count)
- Cash drawer opened successfully count
- Cash drawer failed to opened count
- Number of bar codes printed
- Number of times the max temperature of either the motors or the print heads have been reached

## Notices

This information was developed for products and services offered in the U.S.A.

Toshiba Global Commerce Solutions may not offer the products, services, or features discussed in this document in other countries. Consult your local Toshiba Global Commerce Solutions representative for information on the products and services currently available in your area. Any reference to a Toshiba Global Commerce Solutions product, program, or service is not intended to state or imply that only that Toshiba Global Commerce Solutions product, program, or service may be used. Any functionally equivalent product, program, or service that does not infringe any Toshiba Global Commerce Solutions intellectual property right may be used instead. However, it is the user's responsibility to evaluate and verify the operation of any non-Toshiba Global Commerce Solutions product, program, or service.

Toshiba Global Commerce Solutions may have patents or pending patent applications covering the subject matter in this document. The furnishing of this document does not give you any license to these patents. You can send license inquiries, in writing, to:

Toshiba Global Commerce Solutions  
Attn: General Counsel  
3901 South Miami Blvd.  
Durham, NC 27703  
United States of America

The following paragraph does not apply to the United Kingdom or any other country where such provisions are inconsistent with local law: TOSHIBA GLOBAL COMMERCE SOLUTIONS PROVIDES THIS PUBLICATION "AS IS" WITHOUT WARRANTY OF ANY KIND, EITHER EXPRESS OR IMPLIED, INCLUDING, BUT NOT LIMITED TO, THE IMPLIED WARRANTIES OF NON-INFRINGEMENT, MERCHANTABILITY, OR FITNESS FOR A PARTICULAR PURPOSE. Some states do not allow disclaimer of express or implied warranties in certain transactions, therefore, this statement may not apply to you.

This information could include technical inaccuracies or typographical errors. Changes are periodically made to the information herein; these changes will be incorporated in new editions of the publication. Toshiba Global Commerce Solutions may make improvements and/or changes in the product(s) and/or program(s) described in this publication at any time without notice.

Toshiba Global Commerce Solutions may use or distribute any of the information you supply in any way it believes appropriate without incurring any obligation to you.

Any references in this information to non-Toshiba Global Commerce Solutions Web sites are provided for convenience only and do not in any manner serve as an endorsement of those Web sites. The materials at those Web sites are not part of the materials for this Toshiba Global Commerce Solutions product and use of those Web sites is at your own risk.

Information concerning non-Toshiba Global Commerce Solutions products was obtained from the suppliers of those products, their published announcements or other publicly available sources. Toshiba Global Commerce Solutions has not tested those products and cannot confirm the accuracy of performance, compatibility or any other claims related to non-Toshiba Global Commerce Solutions products. Questions on the capabilities of non-Toshiba Global Commerce Solutions products should be addressed to the suppliers of those products.

This information is for planning purposes only. The information herein is subject to change before the products described become available.

---

## Telecommunication regulatory statement

This product is not intended to be connected directly or indirectly by any means whatsoever to interfaces of public telecommunications networks, nor is it intended to be used in a public services network.

---

## Electronic emission notices

When you attach a monitor to the equipment, you must use the designated monitor cable and any interference suppression devices that are supplied with the monitor.

## Federal Communications Commission (FCC) statement

This equipment has been tested and found to comply with the limits for a Class A digital device, pursuant to Part 15 of the FCC Rules. These limits are designed to provide reasonable protection against harmful interference when the equipment is operated in a commercial environment. This equipment generates, uses, and can radiate radio frequency energy and, if not installed and used in accordance with the instruction manual, may cause harmful interference to radio communications. Operation of this equipment in a residential area is likely to cause harmful interference, in which case the user will be required to correct the interference at his own expense. There is no guarantee that interference will not occur in a particular installation. If this equipment does cause harmful interference to radio or television reception, which can be determined by turning the equipment off and on, the user is encouraged to try to correct the interference by one or more of the following measures:

1. Reorient or relocate the receiving antenna.
2. Increase the separation between the equipment and receiver
3. Connect the equipment into an outlet on a circuit different from that to which the receiver is connected.
4. Consult the dealer or experienced radio TV technician for help.

Properly shielded and grounded cables and connectors must be used in order to meet FCC emission limits. Toshiba Global Commerce Solutions is not responsible for any radio or television interference caused by using other than recommended cables and connectors or by unauthorized changes or modifications to this equipment. Unauthorized changes or modifications could void the user's authority to operate the equipment.

This device complies with part 15 of the FCC Rules. Operation is subject to the following two conditions:

1. This device may not cause harmful interference, and
2. This device must accept any interference received, including interference that may cause undesired operation.

## FCC Radiation Exposure Statement

To comply with the FCC RF exposure compliance requirements, the separation distance between the antenna and the body of all persons must be at least 20 cm (8 inches).

## Industry Canada Class A Emission Compliance statement

This Class A digital apparatus complies with Canadian ICES-003 and RSS247.

Operation is subject to the following two conditions:

1. This device may not cause interference.
2. This device must accept any interference, including interference that may cause undesired operation of the device.



## Avis de conformité à la réglementation d'Industrie Canada

Cet appareil numérique de la classe A est conforme aux normes NMB-003 et RSS247 du Canada.

Le fonctionnement est soumis aux conditions suivantes :

1. Ce périphérique ne doit pas causer d'interférences;
2. Ce périphérique doit accepter toutes les interférences reçues, y compris celles qui risquent d'entraîner un fonctionnement indésirable.

## Industry Canada Radiation Exposure Statement

This equipment complies with IC radiation exposure limits set forth for an uncontrolled environment. This equipment should be installed and operated with a minimum distance of 20 cm (8 inches) from the body of all persons.

## European Union Electromagnetic Compatibility (EMC) Directive Conformance Statement

This product is in conformity with the protection requirements of EU Council Directive 2004/108/EC on the approximation of the laws of the Member States relating to electromagnetic compatibility. Toshiba Global Commerce Solutions cannot accept responsibility for any failure to satisfy the protection requirements resulting from a non-recommended modification of the product, including the fitting of non-Toshiba Global Commerce Solutions option cards.

This product has been tested and found to comply with the limits for Class A Information Technology Equipment according to CISPR 22/European Standard EN 55022. The limits for Class A equipment were derived for commercial and industrial environments to provide reasonable protection against interference with licensed communication equipment.

**Attention:** This is a Class A product. In a domestic environment this product may cause radio interference, in which case the user may be required to take adequate measures.

Responsible manufacturer:

Toshiba Global Commerce Solutions  
3901 South Miami Blvd.  
Durham, NC 27703  
United States of America

European Community contact:

Toshiba Global Commerce Solutions, Inc.  
Brand Manager - Europe, Middle East & Africa  
Toshiba Court, Weybridge Business Park, Addlestone Road, Weybridge, Surrey, KT15 2UL, UK

## Germany Class A statement

**Deutschsprachiger EU Hinweis: Hinweis für Geräte der Klasse A EU-Richtlinie zur Elektromagnetischen Verträglichkeit**

Dieses Produkt entspricht den Schutzanforderungen der EU-Richtlinie 2004/108/EG zur Angleichung der Rechtsvorschriften über die elektromagnetische Verträglichkeit in den EU-Mitgliedsstaaten und hält die Grenzwerte der EN 55022 Klasse A ein.

Um dieses sicherzustellen, sind die Geräte wie in den Handbüchern beschrieben zu installieren und zu betreiben. Des Weiteren dürfen auch nur von der Toshiba Global Commerce Solutions empfohlene Kabel angeschlossen werden. Toshiba Global Commerce Solutions übernimmt keine Verantwortung für die Einhaltung der Schutzanforderungen, wenn das Produkt ohne

Zustimmung der Toshiba Global Commerce Solutions verändert bzw. wenn Erweiterungskomponenten von Fremdherstellern ohne Empfehlung der Toshiba Global Commerce Solutions gesteckt/eingebaut werden.

EN 55022 Klasse A Geräte müssen mit folgendem Warnhinweis versehen werden: "Warnung: Dieses ist eine Einrichtung der Klasse A. Diese Einrichtung kann im Wohnbereich Funk-Störungen verursachen; in diesem Fall kann vom Betreiber verlangt werden, angemessene Maßnahmen zu ergreifen und dafür aufzukommen."

#### **Deutschland: Einhaltung des Gesetzes über die elektromagnetische Verträglichkeit von Geräten**

Dieses Produkt entspricht dem "Gesetz über die elektromagnetische Verträglichkeit von Geräten (EMVG)". Dies ist die Umsetzung der EU-Richtlinie 2004/108/EG in der Bundesrepublik Deutschland.

#### **Zulassungsbescheinigung laut dem Deutschen Gesetz über die elektromagnetische Verträglichkeit von Geräten (EMVG) (bzw. der EMC EG Richtlinie 2004/108/EG) für Geräte der Klasse A**

Dieses Gerät ist berechtigt, in Übereinstimmung mit dem Deutschen EMVG das EG-Konformitätszeichen - CE - zu führen.

Verantwortlich für die Einhaltung der EMV Vorschriften ist der Hersteller:

Toshiba Global Commerce Solutions  
3901 South Miami Blvd.  
Durham, NC 27703  
United States of America

Der verantwortliche Ansprechpartner des Herstellers in der EU ist:

Toshiba Global Commerce Solutions, Inc.  
Brand Manager - Europe, Middle East & Africa  
Toshiba Court, Weybridge Business Park, Addlestone Road, Weybridge, Surrey, KT15 2UL, UK

#### **Generelle Informationen:**

**Das Gerät erfüllt die Schutzanforderungen nach EN 55024 und EN 55022 Klasse A.**

## **Australia and New Zealand Class A statement**

**Attention:** This is a Class A product. In a domestic environment this product may cause radio interference, in which case the user may be required to take adequate measures.

## **Aviso para los usuarios de México**

La operación de este equipo está sujeta a las siguientes dos condiciones:

1. Es posible que este equipo o dispositivo no cause interferencia perjudicial.
2. Este equipo o dispositivo debe aceptar cualquier interferencia. Incluyendo la que pueda causar su operación no deseada.

Para saber el modelo de la tarjeta inalámbrica utilizada, revise la etiqueta regulatoria de la impresora.

## **People's Republic of China Class A electronic emission statement**

**Attention:** This is a Class A product. In a domestic environment this product may cause radio interference, in which case the user may be required to take adequate measures.

## 中华人民共和国“A类”警告声明

### 声明

此为 A 级产品，在生活环境中，该产品可能会造成无线电干扰。在这种情况下，可能需要用户对其干扰采取切实可行的措施。

## Russian Electromagnetic Interference (EMI) Class A statement

ВНИМАНИЕ! Настоящее изделие относится к классу А. В жилых помещениях оно может создавать радиопомехи, снижения которых необходимы дополнительные меры

## Japanese Electrical Appliance and Material Safety Law statement

本製品およびオプションに電源コードセットが付属する場合は、それぞれその装置専用のものでありますので他の機器には使用しないで下さい。

## Japanese power line harmonics compliance statement

高調波ガイドライン適合品

高調波ガイドライン適合品

## Japan Voluntary Control Council for Interference Class A statement

この装置は、クラスA情報技術装置です。この装置を家庭環境で使用すると電波妨害を引き起こすことがあります。この場合には使用者が適切な対策を講ずるよう要求されることがあります。 VCCI-A

**Attention:** This is a Class A product based on the standard of the Voluntary Control Council for Interference (VCCI). If this equipment is used in a domestic environment, radio interference may occur, in which case, the user may be required to take corrective actions.

## Japan Electronics and Information Technology Industries Association (JEITA) statement

高調波ガイドライン適合品

Japan Electronics and Information Technology Industries Association (JEITA) Confirmed Harmonics Guidelines with Modifications (products greater than 20 A per phase).

### **Korean communications statement**

이 기기는 업무용(A급)으로 전자파적합기기로서 판매자 또는 사용자는 이 점을 주의하시기 바라며, 가정외의 지역에서 사용하는 것을 목적으로 합니다.

This is electromagnetic wave compatibility equipment for business (Type A). Sellers and users need to pay attention to it. This is for any areas other than home.

### **Taiwan Class A compliance statement**

警告使用者：  
這是甲類的資訊產品，在居住的環境中使用時，可能會造成射頻干擾，在這種情況下，使用者會被要求採取某些適當的對策。

### **Taiwan contact information**

台灣 TGCS 產品服務聯絡方式：  
台灣東芝全球商業解決方案有限公司  
台北市南港區園區街 3-2 號 5 樓之 1  
電話：0800-001-939

Toshiba Global Commerce Solutions Taiwan Product Service Contact Info:  
Toshiba Global Commerce Solutions, Inc.

## Cable ferrite requirement

All cable ferrites are required to suppress radiated EMI emissions and must not be removed.

---

## Electrostatic discharge (ESD)

**Attention:** Electrostatic discharge (ESD) damage can occur when there is a difference in charge between the part, the product, and the service person. No damage will occur if the service person and the part being installed are at the same charge level.

### ESD damage prevention

Anytime a service action involves physical contact with logic cards, modules, back-panel pins, or other ESD sensitive (ESDS) parts, the service person must be connected to an ESD common ground point on the product through the ESD wrist strap and cord.

The ESD ground clip can be attached to any frame ground, ground braid, green wire ground, or the round ground prong on the AC power plug. Coax or connector outside shells can also be used.

### Handling removed cards

Logic cards removed from a product should be placed in ESD protective containers. No other object should be allowed inside the ESD container with the logic card. Attach tags or reports that must accompany the card to the outside of the container.

---

## Product recycling and disposal

This unit must be recycled or discarded according to applicable local and national regulations. Toshiba Global Commerce Solutions encourages owners of information technology (IT) equipment to responsibly recycle their equipment when it is no longer needed. Toshiba Global Commerce Solutions offers a variety of product return programs and services in several countries to assist equipment owners in recycling their IT products. Information on Toshiba Global Commerce Solutions product recycling offerings can be found on the [Toshiba Global Commerce Solutions product recycling programs website](#).

Español: Esta unidad debe reciclarse o desecharse de acuerdo con lo establecido en la normativa nacional o local aplicable. Toshiba Global Commerce Solutions recomienda a los propietarios de equipos de tecnología de la información (TI) que reciclen responsablemente sus equipos cuando éstos ya no les sean útiles. Toshiba Global Commerce Solutions dispone de una serie de programas y servicios de devolución de productos en varios países, a fin de ayudar a los propietarios de equipos a reciclar sus productos de TI. Se puede encontrar información sobre las ofertas de reciclado de productos de Toshiba Global Commerce Solutions en el sitio web [Toshiba Global Commerce Solutions product recycling programs](#).



**Note:** This mark applies only to countries within the European Union (EU) and Norway.

Appliances are labeled in accordance with European Directive 2002/96/EC concerning waste electrical and electronic equipment (WEEE). The Directive determines the framework for the return and recycling of used appliances as applicable throughout the European Union. This label is applied to various products to indicate that the product is not to be thrown away, but rather reclaimed upon end of life per this Directive.

Remarque : Cette marque s'applique uniquement aux pays de l'Union Européenne et à la Norvège. L'étiquette du système respecte la Directive européenne 2002/96/EC en matière de Déchets des Equipements Electriques et Electroniques (DEEE), qui détermine les dispositions de retour et de recyclage applicables aux systèmes utilisés à travers l'Union européenne. Conformément à la directive, ladite étiquette précise que le produit sur lequel elle est apposée ne doit pas être jeté mais être récupéré en fin de vie.

注意: このマークは EU 諸国およびノルウェーにおいてのみ適用されます。

この機器には、EU 諸国に対する廃電気電子機器指令 2002/96/EC(WEEE) のラベルが貼られています。この指令は、EU 諸国に適用する使用済み機器の回収とリサイクルの骨子を定めています。このラベルは、使用済みになった時に指令に従って適正な処理をする必要があることを知らせるために種々の製品に貼られています。

In accordance with the European WEEE Directive, electrical and electronic equipment (EEE) is to be collected separately and to be reused, recycled, or recovered at end of life. Users of EEE with the WEEE marking per Annex IV of the WEEE Directive, as shown above, must not dispose of end of life EEE as unsorted municipal waste, but use the collection framework available to customers for the return, recycling, and recovery of WEEE. Customer participation is important to minimize any potential effects of EEE on the environment and human health due to the potential presence of hazardous substances in EEE. For proper collection and treatment, contact your local Toshiba Global Commerce Solutions representative.

Disposal of IT products should be in accordance with local ordinances and regulations.

---

## Battery safety



警告: 本電池包含鋰。为避免爆炸, 请勿焚烧电池或对其充电。  
请勿: 把电池投入或浸入水中、把电池加热到 100°C (212°F) 以上、修理或拆卸。 (C003)

### 注 意

用错误型号电池更换会有爆炸危险  
务必按照说明处置用完的电池

**Caution: Risk of explosion if battery is replaced by an incorrect type. Dispose of used batteries according to the instructions.**

警告:  
如果更換不正確之電池型式會有爆炸的風險。  
請依製造商說明書處裡用過之電池。

---

## Battery return program

This product may contain sealed lead acid, nickel cadmium, nickel metal hydride, lithium, or lithium ion battery. Consult your user manual or service manual for specific battery information. The battery must be recycled or disposed of properly. Recycling facilities may not be available in

your area. For information on disposal of batteries outside the United States, go to the [Battery disposal website](#) or contact your local waste disposal facility.

### 电池回收计划

本产品可能包含密封铅酸、镍镉、镍氢、锂或锂离子电池。有关特定的电池信息，请参阅用户手册或维修手册。必须正确地回收或处理这类电池。在您所在的地区中可能没有回收设施。有关在美国之外处理电池的信息，请访问 <http://www.ibm.com/ibm/environment/products/batteryrecycle.shtml>，或与当地的废品处理机构联系。

### For Taiwan:



Please recycle batteries.

### For the European Union:



**Notice:** This mark applies only to countries within the European Union (EU)

Batteries or packaging for batteries are labeled in accordance with European Directive 2006/66/EC concerning batteries and accumulators and waste batteries and accumulators. The Directive determines the framework for the return and recycling of used batteries and accumulators as applicable throughout the European Union. This label is applied to various batteries to indicate that the battery is not to be thrown away, but rather reclaimed upon end of life per this Directive.

Les batteries ou emballages pour batteries sont étiquetés conformément aux directives européennes 2006/66/EC, norme relative aux batteries et accumulateurs en usage et aux batteries et accumulateurs usés. Les directives déterminent la marche à suivre en vigueur dans l'Union Européenne pour le retour et le recyclage des batteries et accumulateurs usés. Cette étiquette est appliquée sur diverses batteries pour indiquer que la batterie ne doit pas être mise au rebut mais plutôt récupérée en fin de cycle de vie selon cette norme.



バッテリーあるいはバッテリー用のパッケージには、EU 諸国に対する廃電気電子機器指令 2006/66/EC のラベルが貼られています。この指令は、バッテリーと蓄電池、および廃棄バッテリーと蓄電池に関するものです。この指令は、使用済みバッテリーと蓄電池の回収とリサイクルの骨子を定めているもので、EU 諸国にわたって適用されます。このラベルは、使用済みになったときに指令に従って適正な処理をする必要があることを知らせるために種々のバッテリーに貼られています。

In accordance with the European Directive 2006/66/EC, batteries and accumulators are labeled to indicate that they are to be collected separately and recycled at end of life. The label on the battery may also include a chemical symbol for the metal concerned in the battery (Pb for lead, Hg for mercury and Cd for cadmium). Users of batteries and accumulators must not dispose of batteries and accumulators as unsorted municipal waste, but use the collection framework available to customers for the return, recycling and treatment of batteries and accumulators. Customer participation is important to minimize any potential effects of batteries and accumulators on the environment and human health due to the potential presence of hazardous substances. For proper collection and treatment, contact your local Toshiba Global Commerce Solutions representative.

This notice is provided in accordance with Royal Decree 106/2008 of Spain: The retail price of batteries, accumulators and power cells includes the cost of the environmental management of their waste.

## For California:

### Perchlorate material – special handling may apply

Refer to [www.dtsc.ca.gov/hazardouswaste/perchlorate](http://www.dtsc.ca.gov/hazardouswaste/perchlorate).

The foregoing notice is provided in accordance with *California Code of Regulations Title 22, Division 4.5, Chapter 33: Best Management Practices for Perchlorate Materials*. This product/part includes a lithium manganese dioxide battery which contains a perchlorate substance.

---

## Flat panel displays

The fluorescent lamp in the liquid crystal display contains mercury. Dispose of it as required by local ordinances and regulations.

---

## Monitors and workstations

Connecticut: Visit the website of the Department of Energy & Environmental Protection at [www.ct.gov/deep](http://www.ct.gov/deep) for information about recycling covered electronic devices in the State of Connecticut, or telephone the Connecticut Department of Environmental Protection at 1-860-424-3000.

Oregon: For information regarding recycling covered electronic devices in the state of Oregon, go to the Oregon Department of Environmental Quality site at [www.deq.state.or.us/kj/electronics.htm](http://www.deq.state.or.us/kj/electronics.htm).

Washington: For information about recycling covered electronic devices in the State of Washington, go to the Department of Ecology Website at [fortress.wa.gov/ecy/recycle/](http://fortress.wa.gov/ecy/recycle/) or telephone the Washington Department of Ecology at 1-800-Recycle.

---

## Trademarks

The following are trademarks or registered trademarks of Toshiba, Inc. in the United States or other countries, or both:



Toshiba  
The Toshiba logo

The following are trademarks of Toshiba Global Commerce Solutions in the United States or other countries, or both:

AnyPlace  
SureMark  
SurePoint  
SurePOS  
TCxWave  
TCxFlight  
TCx

The following are trademarks of International Business Machines Corporation in the United States or other countries, or both:

DB2  
DB2 Universal Database  
IBM and the IBM logo  
PS/2  
Wake on LAN  
WebSphere

Linux is a trademark of Linus Torvalds in the United States, other countries, or both.

Magellan is a registered trademark of Datalogic Scanning, Inc.

SYMBOL a registered trademark of Symbol Technologies, Inc.

Microsoft, Windows, Windows NT, and the Windows 95 logo are trademarks of Microsoft Corporation in the United States, other countries, or both.

Celeron and Intel are trademarks of Intel corporation in the United States, or other countries.

Oracle, JVM and Java are registered trademarks of Oracle and/or its affiliates.

Other company, product, or service names may be trademarks or service marks of others.



---

# Index

45-degree mounting 30

## B

battery return program 46  
before you begin 27

## C

cable ferrite requirement 45  
calling for service 22  
Class A compliance statement  
  Australia and New Zealand 42  
  China 42  
  European Union 41  
  FCC (USA) 40  
  Germany 41  
  Industry Canada 40  
  Japan 43  
  Russia 43  
cleaning recommendations 36  
communication interfaces  
  Ethernet interface card 16  
  RS-232 interface card 15  
  RS-485 interface card 16  
  USB interface card 15  
controls and indicators 20

## D

damage from electrostatic discharge 45  
dimensions, physical 25  
disposal of equipment 45

## E

edition notice  
electromagnetic Interference statement  
  Russia 43  
electronic emissions notices  
  Australia and New Zealand 42  
  China 42  
  European Union 41  
  FCC (USA) 40  
  Germany 41  
  Industry Canada 40  
  Japan 43  
  Korea 44  
electrostatic discharge (ESD) 45  
end of life disposal 45  
equipment disposal 45  
Ethernet  
  interface card 16  
European Union battery recycling  
statement 47

## F

ferrite requirement 45  
fillers, installing 30  
flat panel displays 48

## H

hardware adjustment procedures 35  
hardware requirements 19  
height, all models 25  
humidity requirements 26

## I

installation, thermal/impact  
  unpacking 27  
installing  
  fillers 30  
  interface card 27  
  large paper rolls 36  
interface card  
  installing 27  
interfaces, communication 14  
introduction 13

## J

Japan Electronics and Information  
Technology Industries Association  
statement 43  
Japanese Electrical Appliance and Material  
Safety Law statement 43  
Japanese power line harmonics compliance  
statement 43  
Japanese VCCI Council Class A  
statement 43

## K

Korean communications statement 44

## L

loading and replacing the paper roll 35  
locating the power button 21

## M

mercury-added statement 48  
model and feature description 14  
model number location 22  
models and features 13  
mounting

mounting (*continued*)  
  45 degree 30  
  wall 30

## N

Network (Ethernet and WiFi) interface  
adapter prerequisites 18  
notices  
  battery recycling 47  
  cable ferrites 45  
  electronic emissions 40  
  electrostatic discharge (ESD) 45  
  end of life disposal 45  
  Toshiba 39

## O

opening the paper door 35  
operating system requirements 18

## P

paper  
  large rolls 36  
  supported types 35  
  thermal specifications 35  
paper roll placement 35  
paper roll, loading and replacing 35  
perchlorate 48  
physical dimensions 25  
power button  
  location 21  
printer statistics 37  
printer, thermal/impact  
  indicators and controls 20  
  operation 20  
printhead cleaning, thermal head 36  
product specifications 25  
publications, 11

## R

retrieving printer statistics 37  
RS-232  
  interface card 15  
RS-485  
  interface card 16

## S

safety information 9  
serial number location 22  
statistics, printer 37  
supported paper types 35

## T

- Taiwanese battery recycling statement [47](#)
- Telecommunications regulatory statement [40](#)
- temperature requirements [26](#)
- thermal paper specifications [35](#)
- Toshiba Global Commerce Solutions
  - support site
  - website [11](#)
- trademarks [48](#)

## U

- understanding the controls and indicators [20](#)
- understanding your configuration [27](#)
- unpacking the printer [27](#)
- USB
  - interface card [15](#)

## W

- wall mounting [30](#)
- weight, all models [25](#)
- WiFi [17](#)
- WiFi interface card
  - interface card [17](#)



